

JCE Series



- 2:1 Input Range
- DIP-24 Plastic Case
- Operating Temperature $-40\text{ }^{\circ}\text{C}$ to $+100\text{ }^{\circ}\text{C}$
- Single & Dual Outputs
- Optional Metal Case
- 1500 VDC Isolation, 3000 VDC Option
- 3 Year Warranty

Specification

Input

Input Voltage Range	<ul style="list-style-type: none"> • 12 V (9-18 VDC) • 24 V (18-36 VDC) • 48 V (36-75 VDC)
Input Current	<ul style="list-style-type: none"> • See table
Input Filter	<ul style="list-style-type: none"> • Pi network
Input Reflected Ripple	<ul style="list-style-type: none"> • 20 mA pk-pk through 12 μH inductor and 4.7 μF capacitor
Input Surge	<ul style="list-style-type: none"> • 12 V models 25 VDC for 100 ms • 24 V models 50 VDC for 100 ms • 48 V models 100 VDC for 100 ms
Under Voltage Lockout	<ul style="list-style-type: none"> • 12 V models on $>8.5\text{ V}$, off $<8.0\text{ V}$ • 24 V models on $>16.5\text{ V}$, off $<15.5\text{ V}$ • 48 V models on $>34.5\text{ V}$, off $<33.5\text{ V}$

Output

Output Voltage	<ul style="list-style-type: none"> • See table
Output Voltage Balance	<ul style="list-style-type: none"> • $\pm 2\%$ max, dual output models
Initial Set Accuracy	<ul style="list-style-type: none"> • $\pm 2\%$ max
Minimum Load	<ul style="list-style-type: none"> • No minimum load required
Line Regulation	<ul style="list-style-type: none"> • $\pm 0.5\%$ max
Load Regulation	<ul style="list-style-type: none"> • $\pm 1.2\%$ max, for single output and $\pm 5\%$ max for dual output from 10-100%
Cross Regulation	<ul style="list-style-type: none"> • $\pm 5\%$ max, on dual output models (see note 1)
Start Up Delay	<ul style="list-style-type: none"> • 20 ms typical
Ripple & Noise	<ul style="list-style-type: none"> • 80 mV pk-pk (100 mV for D24 models), 20 MHz bandwidth. See note 2
Transient Response	<ul style="list-style-type: none"> • 3% max deviation, recovery to within 1% in 300 μs for a 25% load change (4% max. deviation for S3V3 models)
Overload Protection	<ul style="list-style-type: none"> • 135% - 185% of full load
Short Circuit Protection	<ul style="list-style-type: none"> • Trip and restart (hiccup mode), auto recovery
Maximum Capacitive Load	<ul style="list-style-type: none"> • See table
Temperature Coefficient	<ul style="list-style-type: none"> • $0.02\%/^{\circ}\text{C}$ max

General

Efficiency	<ul style="list-style-type: none"> • See table
Isolation Voltage	<ul style="list-style-type: none"> • 1500 VDC Input to Output • For optional high isolation versions 3000 VDC Input to Output add suffix -H to model number • 1000 VDC Input to Case • 1000 VDC Output to Case
Isolation Capacitance	<ul style="list-style-type: none"> • 1000 pF typical input to output
Isolation Resistance	<ul style="list-style-type: none"> • $10^9\Omega$
Switching Frequency	<ul style="list-style-type: none"> • 330 kHz typical
Power Density	<ul style="list-style-type: none"> • 15 W/in^3
MTBF	<ul style="list-style-type: none"> • $>800\text{ KHrs}$ to MIL-STD-217F at $25\text{ }^{\circ}\text{C}$, GB

Environmental

Operating Temperature	<ul style="list-style-type: none"> • $-40\text{ }^{\circ}\text{C}$ to $+100\text{ }^{\circ}\text{C}$ (see derating curve)
Case Temperature	<ul style="list-style-type: none"> • $+100\text{ }^{\circ}\text{C}$ max
Storage Temperature	<ul style="list-style-type: none"> • $-55\text{ }^{\circ}\text{C}$ to $+125\text{ }^{\circ}\text{C}$
Cooling	<ul style="list-style-type: none"> • Convection-cooled
Operating Humidity	<ul style="list-style-type: none"> • Up to 95% RH, non-condensing

EMC

Emissions	<ul style="list-style-type: none"> • EN55032 Class A conducted
ESD Immunity	<ul style="list-style-type: none"> • EN61000-4-2, level 3, Perf Criteria B
Radiated Immunity	<ul style="list-style-type: none"> • EN61000-4-3, 10 V/m, Perf Criteria A
EFT/Burst	<ul style="list-style-type: none"> • EN61000-4-4, level 3 Perf Criteria A
Surge	<ul style="list-style-type: none"> • EN61000-4-5, level 2, Perf Criteria A*
Conducted Immunity	<ul style="list-style-type: none"> • EN61000-4-6, 10 Vrms, Perf Criteria A*
Magnetic Field	<ul style="list-style-type: none"> • EN61000-4-8, 1 A/m, Perf Criteria A

Safety

Safety Approvals	<ul style="list-style-type: none"> • UL62368-1, CAN/CSA C22.2 No. 62368-1 and 62368-1
------------------	--

* External input capacitor required, 220 μF /100V (See note 7)

Models and Ratings

Input Voltage	Output Voltage	Output Current	Input Current ⁽¹⁾		Maximum Capacitive Load ⁽⁶⁾	Efficiency	Model Number ^(4,5)
			No Load	Full Load			
9-18 VDC	3.3 V	1400 mA	7 mA	513 mA	470 μ F	75%	JCE0612S3V3
	5.0 V	1200 mA	7 mA	633 mA	470 μ F	79%	JCE0612S05
	12.0 V	500 mA	10 mA	602 mA	100 μ F	83%	JCE0612S12
	15.0 V	400 mA	10 mA	595 mA	100 μ F	84%	JCE0612S15
	24.0 V	250 mA	20 mA	610 mA	47 μ F	82%	JCE0612S24
	± 3.3 V	± 909 mA	10 mA	658 mA	± 220 μ F	76%	JCE0612D03
	± 5.0 V	± 600 mA	10 mA	625 mA	± 220 μ F	80%	JCE0612D05
	± 12.0 V	± 250 mA	15 mA	602 mA	± 100 μ F	83%	JCE0612D12
	± 15.0 V	± 200 mA	20 mA	595 mA	± 100 μ F	84%	JCE0612D15
18-36 VDC	3.3 V	1400 mA	7 mA	260 mA	470 μ F	74%	JCE0624S3V3
	5.0 V	1200 mA	7 mA	316 mA	470 μ F	79%	JCE0624S05
	12.0 V	500 mA	7 mA	301 mA	100 μ F	83%	JCE0624S12
	15.0 V	400 mA	7 mA	301 mA	100 μ F	83%	JCE0624S15
	24.0 V	250 mA	10 mA	305 mA	47 μ F	82%	JCE0624S24
	± 3.3 V	± 909 mA	7 mA	329 mA	± 220 μ F	76%	JCE0624D03
	± 5.0 V	± 600 mA	7 mA	312 mA	± 220 μ F	80%	JCE0624D05
	± 12.0 V	± 250 mA	10 mA	301 mA	± 100 μ F	83%	JCE0624D12
	± 15.0 V	± 200 mA	15 mA	298 mA	± 100 μ F	84%	JCE0624D15
36-75 VDC	3.3 V	1400 mA	7 mA	128 mA	470 μ F	76%	JCE0648S3V3
	5.0 V	1200 mA	7 mA	154 mA	470 μ F	82%	JCE0648S05
	12.0 V	500 mA	7 mA	151 mA	100 μ F	84%	JCE0648S12
	15.0 V	400 mA	7 mA	151 mA	100 μ F	84%	JCE0648S15
	24.0 V	250 mA	7 mA	151 mA	47 μ F	84%	JCE0648S24
	± 3.3 V	± 909 mA	7 mA	162 mA	± 220 μ F	78%	JCE0648D03
	± 5.0 V	± 600 mA	7 mA	154 mA	± 220 μ F	82%	JCE0648D05
	± 12.0 V	± 250 mA	7 mA	151 mA	± 100 μ F	84%	JCE0648D12
	± 15.0 V	± 200 mA	7 mA	151 mA	± 100 μ F	84%	JCE0648D15
	± 24.0 V	± 125 mA	15 mA	158 mA	± 47 μ F	80%	JCE0648D24

Notes

- When one output is set at 100% load and the other varies between 25% & 100% load.
- Measured with 20 MHz bandwidth and 1 μ F ceramic capacitor across output rails.
- Input current specified at nominal 12 V, 24 V or 48 V input.
- For optional 3000 VDC isolation add suffix -H to part number e.g. JCE0624S12-H
- For optional metal case version add suffix -M to part number e.g. JCE0612S24-M
- Maximum capacitive load is per output
- For surge immunity, external input capacitor required, 220 μ F/100 V, 24 V & 48 V input models are Perf Criteria A, 12 V input models are Perf Criteria B.

Mechanical Details

Plastic Case

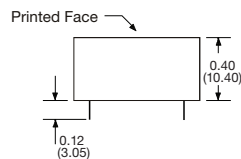
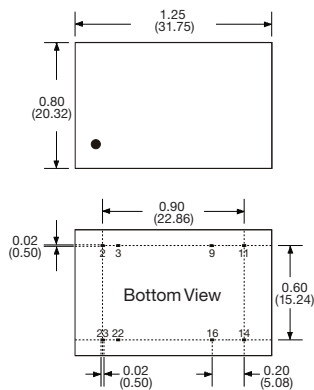

Pin	Single	Dual
2	-Vin	-Vin
3	-Vin	-Vin
9	No Pin	Common
11	N.C.	-Vout
14	+Vout	+Vout
16	-Vout	Common
22	+Vin	+Vin
23	+Vin	+Vin

Optional Metal Case

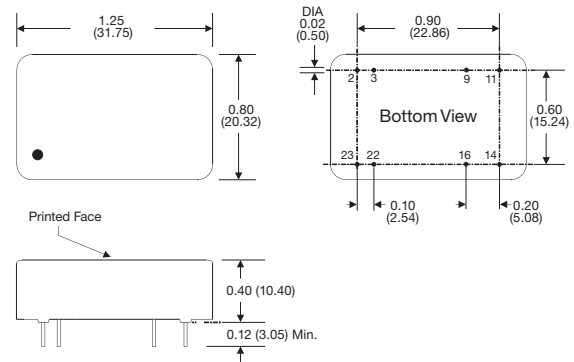

Notes

- All dimensions are in inches (mm)
- Weight: 0.03 lbs (13 g) for plastic case, 0.04 lbs (16.5 g) for metal case
- Pin diameter: 0.02 \pm 0.002 (0.5 \pm 0.005)
- Pin pitch and length tolerance: \pm 0.014 (\pm 0.35)
- Case tolerance: \pm 0.02 (\pm 0.5)
- Package: 24 pin DIL black plastic (UL94V-0) or optional nickel-coated copper.

Application Notes

Derating Curve

